

SALOMIX™ and Scaba top-mounted agitators







Mixing technology for a more efficient and reliable operation

Sulzer provides highly efficient mixing and agitation solutions for a wide range of industries. Our top-mounted vertical agitators and side-mounted horizontal agitators use SALOMIX™ and Scaba technology, to ensure minimal power consumption, reliable operation and optimum process results. Our vast wealth of experience across the industries has enabled us to develop smart solutions and concepts, such as unique selection criteria and heavy-duty modular design.

Process knowledge

When selecting an agitator, you must bear in mind your tank size and shape, mixing purpose and type of liquid. Knowing how to predict the degree of agitation – in any tank and for any liquid – is a crucial part of the selection process.

Thanks to our extensive knowhow, we understand your processes and have developed a number of smart solutions, spanning from mild flocculation to keeping solid rocks in suspension and anaerobic digestion for biogas production. Thousands of installations in industries such as wastewater, pulp and paper, biofuels, fertilizers, chemical processing, food and beverages, pharmaceutical and metal and mining, prove our knowhow and experience as a supplier.

Efficient operation

Sulzer provides maximum efficiency propellers, optimized by extensive laboratory testing and advanced Computational Fluid Dynamics (CFD) calculations.

Selecting the right size of agitator is just as important when it comes to reducing power consumption. Using an oversized agitator may complete the task, but it will be very costly – more agitation means more power input.

Sulzer gives you the combination of optimum agitator selection and maximum propeller efficiency, which will significantly reduce your overall power consumption.

Reliability

There are a number of factors that affect the reliability of your agitator, such as product design, manufacturing processes and aftermarket service and support. Our extensive portfolio of testimonials from a wide range of industries around the world confirms the reliability of Sulzer products.

Service

Our network of local service centers ensures fast response times and superior customer service. In addition to supplying original spare parts, we are also close by to help you optimize your agitators and reach your process performance, reliability and safety targets.

Research and development

The Sulzer Research Center in Karhula, Finland, uses a 30 m³ mixing tank and full-scale agitators to study the agitation of different liquids, including suspensions. When designing new propellers, we carry out experimental studies, along with numerical simulations using CFD.

Scaba top-mounted agitators

These robust, modular, heavy-duty agitators are highly flexible and can be standardized or tailor-made for each individual application. They can be combined with a range of different drives, propellers, shaft lengths and seals.

Scaba – modular-based design

- A wide product range for different applications
- Commonly used in wastewater treatment plants
- Standardized range available through the Scaba TreatX concept with sharpened prices and lead times
- Also suitable for other industries, such as biogas production, metals and mining, and pulp and paper
- Available for 50 and 60 Hz, both for IEC and NEMA motors

Features

- Power up to 400 kW
- Shaft diameter 20-220 mm
- Shaft length up to 30 m in 6 stages
- Various seal options
- Optional bottom steady bearing

Impellers

Scaba SHP1 and SHP18 propellers create a high axial flow, pumping with same capacity through the entire propeller diameter. Thanks to the constant pitch and low gliding ratio Scaba propellers can give surprisingly low power consumption.



3SHP1



3SHP18

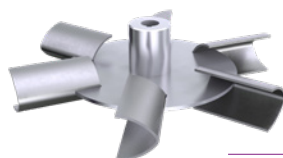







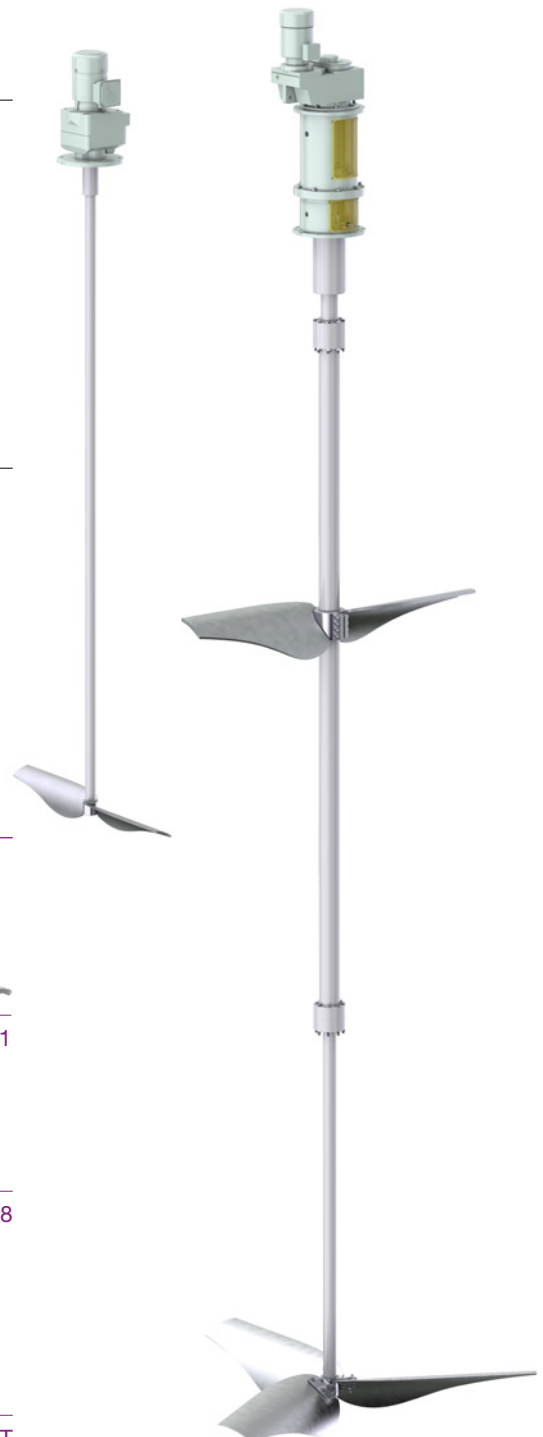

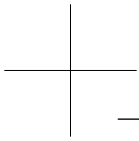







SRGT

Impeller options

- Propellers and turbines
- Diameter 90-8'000 mm
- Up to 6 propellers



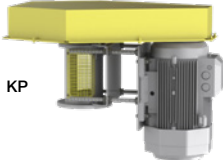
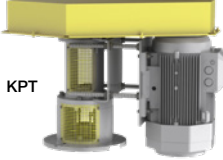

	(-) Direct drive or gear box only	(P) Bearing housing	(PT) Bearing and seal housing	(T) Seal housing
D-model	 D	 DP	 DPT	 DT
V-model	 V	 VP	 VPT	
FV-model	 FV	 FVP	 FVPT	 FVT
VW-model	 VW	 VWP	 VWPT	 VWT
KP-model		 KP	 KPT	

Labyrinth seal

A labyrinth seal is typically used in digesters to prevent gas from leaking out from the tank. A water column creates a pressure lock so that the gas cannot leave the tank. A level indicator shows the water pressure in the seal.

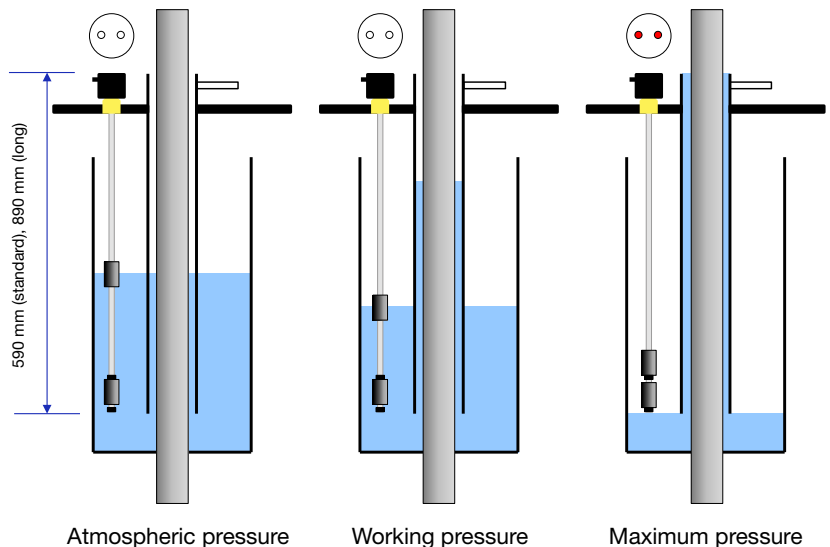

SALOMIX™ top-mounted agitator

These robust, modular, heavy-duty agitators are highly flexible and can be tailor-made for each individual application. They can be combined with a range of different drives, propellers, shaft lengths and seals. They are very popular in a wide range of industries, such as pulp and paper, fertilizers, biofuels and food industry.

Features

- Power range 1 to 400 kW
- Shaft length up to 25 meter
- Paddle diameter up to 8'000 mm
- Propeller diameters up to 1'600 mm
- Optional bottom steady bearing

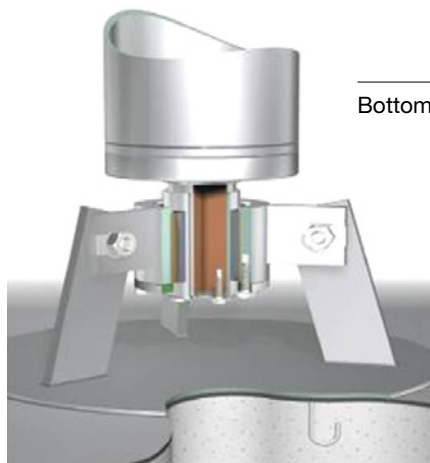

Bottom bearing

Impellers

AF paddle type impellers are commonly used in SALOMIX top-mounted agitators for storage applications. SALOMIX AF pitched blades create strong axial flow and keep the solids in constant motion all over the tank. Other impeller types, such as propellers and turbines, are available for blending, dispersion or other applications.

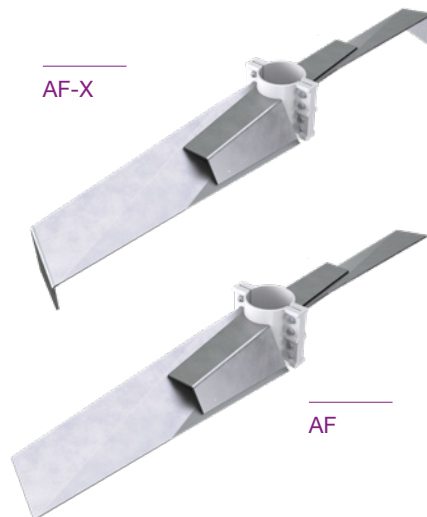

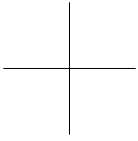

LM direct drive



LV gear drive



LA belt drive
(optional seal housing)



L gear drive with
bearing housing
(optional seal housing)



Seals

A lip seal can be used to prevent gases and fumes from leaking out from the tank. This seal is a dry-run seal that can be used for pressures up to 3 bar. For higher pressures and pressure tanks, mechanical seals can be used.

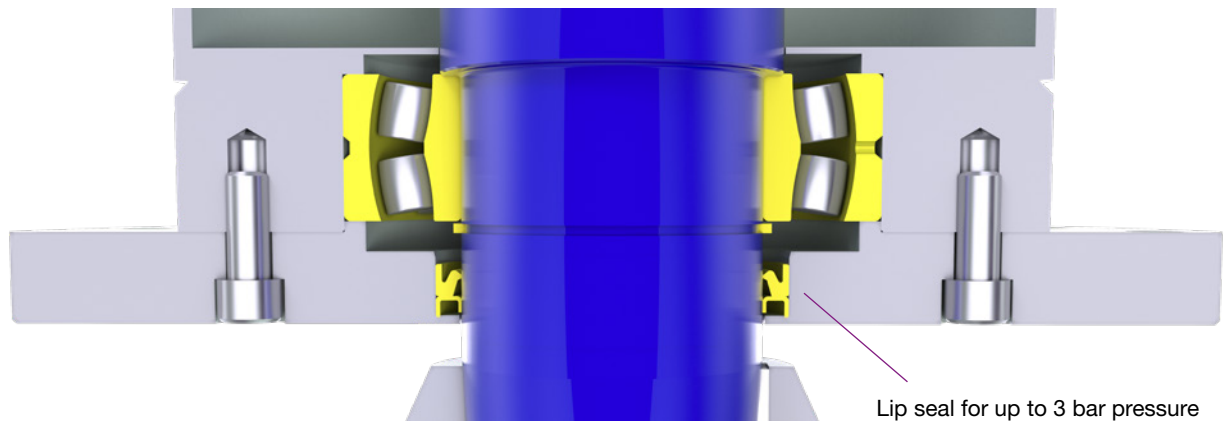

Water and wastewater industry

There are many crucial applications in municipal and industrial water and wastewater industry. At Sulzer, we understand the challenges you face and can help you to keep operational efficiency and produce clean water, every single day.

Flash mixing

Flash mixers rapidly blend in chemicals, typically added at the beginning of the flocculation process. This requires intensive mixing to achieve even distribution, but normally only a small, direct-driven agitator without gear is needed.

Flocculation

In flocculation process very gentle mixing is required to allow increasingly large flocs to form without being broken apart by the mixing blades, at the same time avoiding sedimentation. Sulzer offers unique flocculation solutions that secure floc build-up and allow for perfect process control. Typically, flocculation agitators are slow-running with relatively large propellers.

Nitrification/denitrification

To remove nitrogen from wastewater, treatment plants commonly use the nitrification/denitrification process. During the denitrification process agitation is required to avoid sedimentation while ensuring no air is drawn in.

Flash mixers, flocculation and denitrification agitators are available through the Scaba TreatX concept with pre-engineered agitators.

Anaerobic digester

Treating sludge in an anaerobic digester is getting more and more common. Sludge may come from manure, animal slaughter, wastewater treatment or other source, but the process allows gaining energy through biogas generation and still keeping the nutrients in the loop. A top-mounted agitator is the absolutely most effective way to keep the organics homogeneous and ensures even temperature distribution. In Sulzer, we have vast experience in designing such large free-hanging agitators. Our efficient propellers and unique designing methods ensure surprisingly low power consumption.



Denitrification can be an intermittent aeration process with anoxic and aerobic phases created alternately.

Computational Fluid Dynamics (CFD)

CFD analysis can be performed on actual tank and agitator combinations to verify the desired process result. Sulzer has long experience using CFD simulations.

A simulation of an agitator in a large digester shows even flow that guarantees good temperature distribution and high gas production.

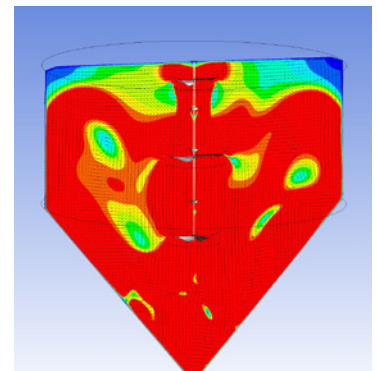

Pulp and paper industry

Top-mounted agitators are widely used in many main processes in pulp and paper production and in the wastewater treatment plant. The most demanding applications are in the recovery plant, where used liquids from the fiber line are chemically treated for re-use in the cooking process.

Recausticizing plant

In a causticizing reactor a vertical agitator is used for mixing the slurry and to prevent sedimentation.

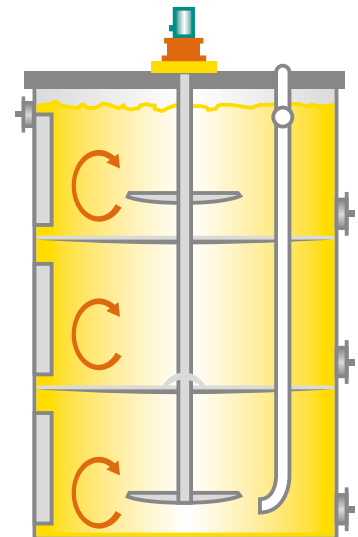
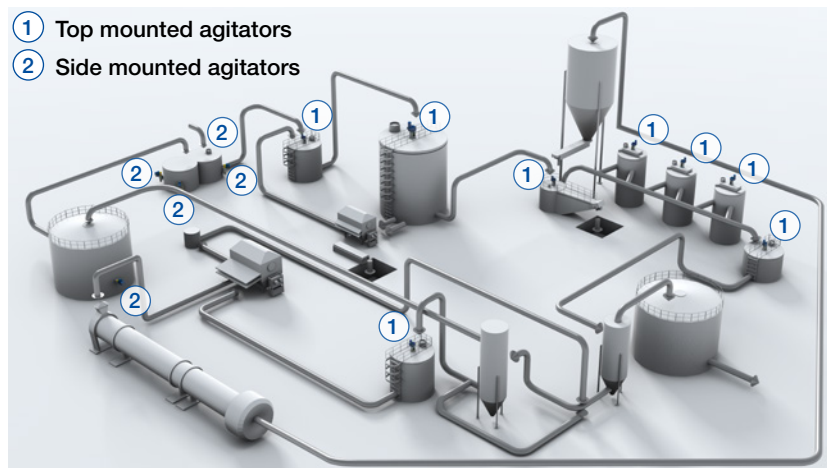

Storage tanks with vertical agitators

Fillers, pigments and other additives are common in paper production. To keep the slurry homogenous, vertical agitators with propellers or paddles are used.

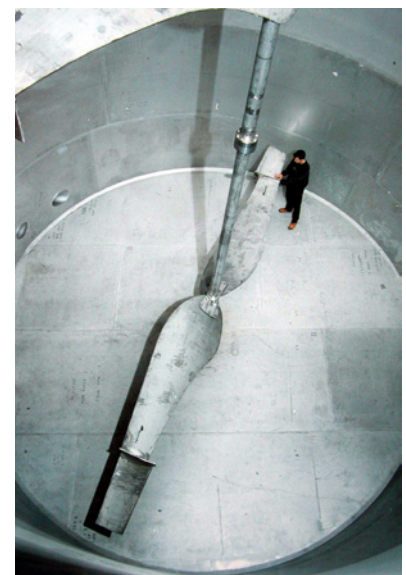

Vertical agitator for paper chemicals. Double-acting propeller for viscous liquids and pulp applications.

Fertilizers and chemical process industry

SALOMIX and Scaba top-mounted agitators are used in several applications in the chemical process industry. One example is the production of phosphoric acid for the fertilizer industry. Sulzer has a proven solution for a solid-liquid mixing process in highly corrosive and abrasive conditions.

Material technology

Sulzer has long experience of supplying various advanced materials for demanding industrial applications.

Example of stainless steel materials:

- Austenitic stainless steel
- Duplex stainless steel
- Super duplex
- SMO

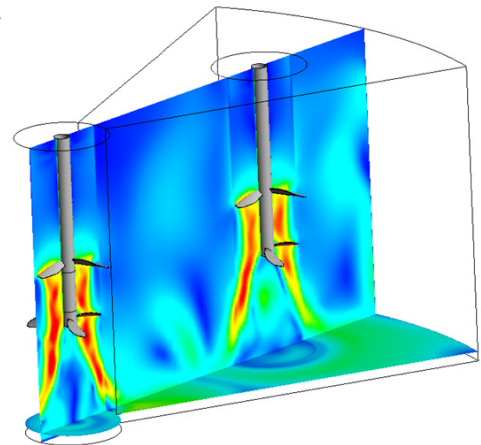
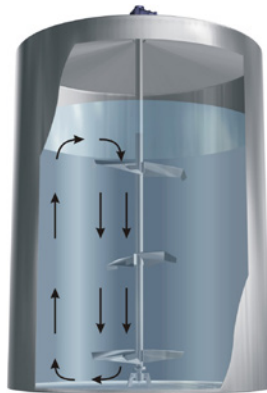

CFD simulation of an attack tank in phosphoric acid production.

Mining and metals industry

Sulzer has vast experience in delivering agitators to metal refineries and mining industries, such as copper, zinc, nickel, aluminum, iron and steel. A common challenge is to properly size the agitator to keep heavy mineral particles in suspension, while securing a stable and reliable process. Media are often both erosive and very corrosive, requiring advanced materials and lined agitators.

Lining of agitators

Sulzer offers suitable lining for all sizes of agitators used with aggressive media. Rubber lining is commonly used in mineral slurries, but other lining materials, such as polyurethane, are also available. Lining can be combined with advanced materials, such as duplex or super duplex steel.

Rubber lined propellers for mineral suspension.

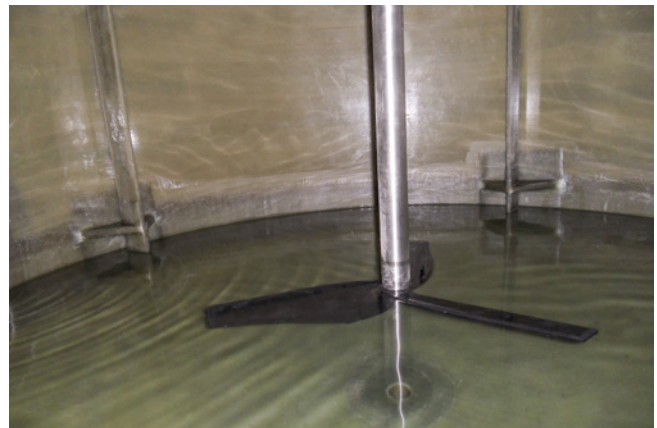

Food and beverage industry

Demand within the food industry varies a lot. While the sugar industry focuses on robustness and reliability, other segments require systems with hygienic design. Choosing Sulzer you are able to get both. Many food industries deal with non-Newtonian fluids, such as yoghurt, ketchup and starch. To optimize the production process it is necessary to predict and secure the correct agitation level.

Hygienic design

Scaba agitators can be specially designed for high hygiene levels. The construction ensures no dead spots for bacteria growth with higher surface finish on the parts. Food grade oil can be used for gear lubrication and a special TH flange prevents any leakage from outside to enter the tank. Choose either eccentric design with no baffles, or design with hygienic baffles.

Homogenization of ketchup with a Scaba agitator with hygienic design.

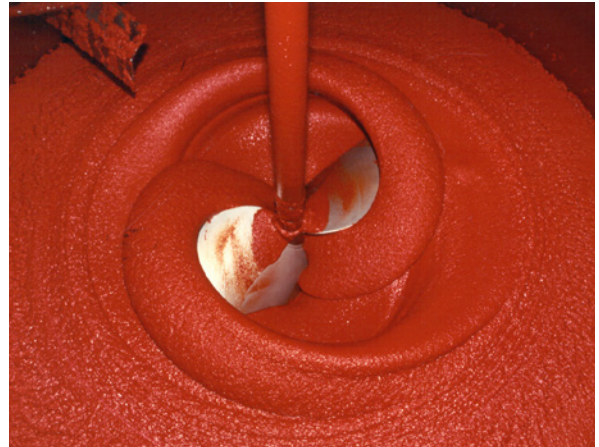

Biofuels industry

Biofuels are a key factor in sustainable production. The biofuels market is constantly finding new sources and production methods and as the processes change, so do the demands for agitation. With vast experience in supplying agitators to bioethanol, biodiesel and biogas production, Sulzer can easily meet both current and future challenges of various feedstocks.

Explosion-proof design

SALOMIX and Scaba vertical agitators are ATEX certified for use in zone 1 and zone 2, which makes them highly suitable for the biofuels industry.





The Sulzer Flow Equipment division keeps your processes flowing. Wherever fluids are treated, pumped, or mixed, we deliver highly innovative and reliable solutions for the most demanding applications.

The Flow Equipment division specializes in pumping solutions specifically engineered for the processes of our customers. We provide pumps, agitators, compressors, grinders, screens and filters developed through intensive research and development in fluid dynamics and advanced materials. We are a market leader in pumping solutions for water, oil and gas, power, chemicals and most industrial segments.

E10367 en 1.2023, Copyright © Sulzer Ltd 2023

This brochure is a general presentation. It does not provide any warranty or guarantee of any kind. Please, contact us for a description of the warranties and guarantees offered with our products. Directions for use and safety will be given separately. All information herein is subject to change without notice.

